

REV.	ZONE	DESCRIPTION	DESIGN	DATE
A		初版发行	Jack	15.04.08
B		增加尺寸标注	Jack	15.08.06

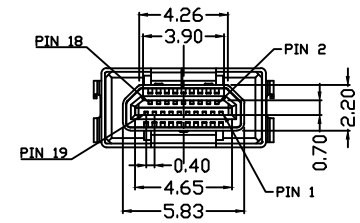
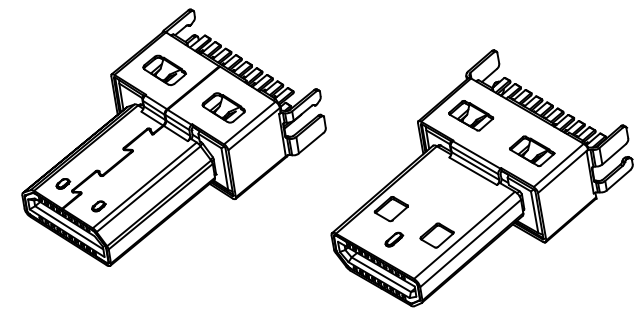
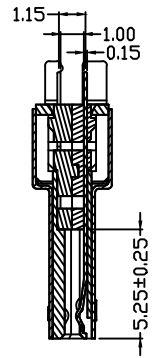
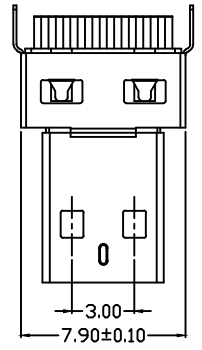
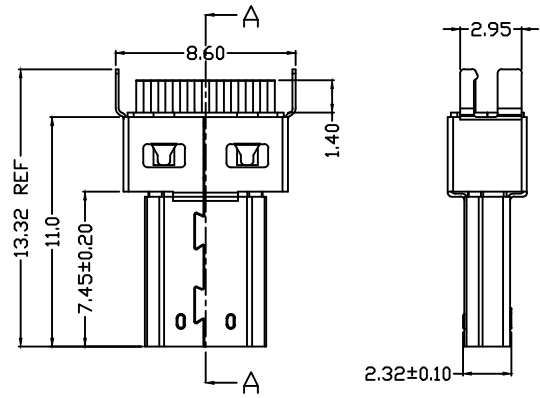
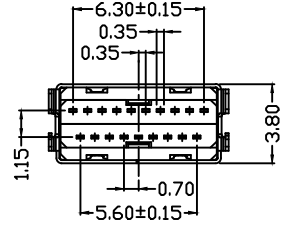

SPECIFICATION
***ELECTRICAL**
 1. CONTACT RESISTANCE: 30mΩ MAX.
 2. rated voltage: 30V
 3. INSULATION RESISTANCE: 100MΩ MIN.
 4. RATE CURRENT: 0.8A.
***MECHANICAL**
 1. INSERTION FORCE: 4.5kg maximum
 2. EXTRACTION FORCE: 0.5(kg) MIN.
 3. Temperature range: -25°C ~ 85°C
 4. working life: 5000 cycles.

PIN NO	SINGAL NO	PIN NO	SINGAL NO
PIN 1	Hot Plug Detect	PIN 2	Utility
PIN 3	TMD5 Data2+	PIN 4	TMD5 Data2 Shield
PIN 5	TMD5 Data2-	PIN 6	TMD5 Data1+
PIN 7	TMD5 Data1 Shield	PIN 8	TMD5 Data1-
PIN 9	TMD5 Data0+	PIN 10	TMD5 Data0 Shield
PIN 11	TMD5 Data0-	PIN 12	TMD5 Clock+
PIN 13	TMD5 Clock Shield	PIN 14	TMD5 Clock-
PIN 15	CEC	PIN 16	DDC/CEC Ground
PIN 17	SCL	PIN 18	SDA
PIN 19	+5V Power		

ITEM	PART NAME	Q'TY/EA	MATERIALS	NOTE
④	SHELL	1	C2680-H T=0.15mm	Plating: Ni100μ, Au3μ
⑤	Housing	1	LCP (black)	UL94V-0
②	10P CONTACT	1	C5191-H T=0.15mm	Plating: Ni100μ, Sn:100μ, Au3μ
①	9P CONTACT	1	C5191-H T=0.15mm	Plating: Ni100μ, Sn:100μ, Au3μ

Unless otherwise specified tolerances are

X, X	±0.20
X, XX	±0.15
X, XXX	±0.10
X°	±2.0°
X, X°	±1.0°

Coorle 库乐科技

DRAW NO.	ZQ-13-0099	DATE	15. 08. 06	DRAW NAME:	HDMI D TYPE 公头 夹板式
CHK	Jack			P/N :	
APVD					

FINISH		UNIT	SCALE	WEIGHT	REV	SHEET
MATERIAL		mm	1:1		B	1 OF 1

Third Angle Project